

Link do produktu: <https://sklep.akcesoria-cnc.pl/przekladnia-slimakowa-nmr030-50-501-p-168.html>



## Przekładnia ślimakowa NMRV030-50 50:1

Cena brutto	<b>335,00 zł</b>
Cena netto	<b>272,36 zł</b>
Dostępność	<b>Dostępny</b>
Czas wysyłki	<b>24 godziny</b>
Kod producenta	<b>NMRV-030</b>
Kod producenta	<b>NMRV-030</b>
Marka	<b>ZAX</b>
Model	<b>PX57N36</b>
Waga produktu z opakowaniem jednostkowym	<b>1 kg</b>
Stan opakowania	<b>oryginalne</b>

### Opis produktu

Przekładnia kątowna ślimakowa do silników:  
BLDC, DC, serwo, serwo-krokowych NEMA23 (57mm)

Przekładnia współpracuje z każdym silnikiem z kołnierzem o rozmiarach 57x57mm

### Parametry przekładni

- przełożenie 50:1
- moment obrotowy znamionowy 23Nm
- wymiary 100x95x56mm
- do silnika rozmiaru NEMA 23 (57mm)
- rozstaw otworów mocujących silnik 47.1mm
- wał wejściowy silnika - 8mm (11mm)
- otwór na wał wyjściowy fi 14mm
- waga 1,1kg

W zestawie:

- przekładnia
- reduktor na wał 8mm

Model	Diameter(mm)		Matched Motor			Allowable max Torque
	Input	Output	BLDC motor	Stepper motor	Servo motor	
RV30	8 or 6.5mm	14mm	180w, 57mm	57mm	-	18Nm
RV40	14mm	18mm	400w, 80 and 86mm	86mm	60mm	50Nm
RV50	14 or 19mm	25mm	750w, 80 and 86mm	86mm,110mm	80mm,110mm	80Nm
RV63	19,22 or 24mm	25mm	1000w, 86 and 110mm	110mm	130mm	120Nm



## NMRV030

**Gear ratio:** 5 7.5 10 15 20 25  
30 40 50 60 80

Standard input shaft dia: 9 or 11mm  
8 and 6.35mm are also optional

Output shaft dia: 14mm with  
5mm keyway

**For Nema34 stepper motor**

### Wymiary przekładni

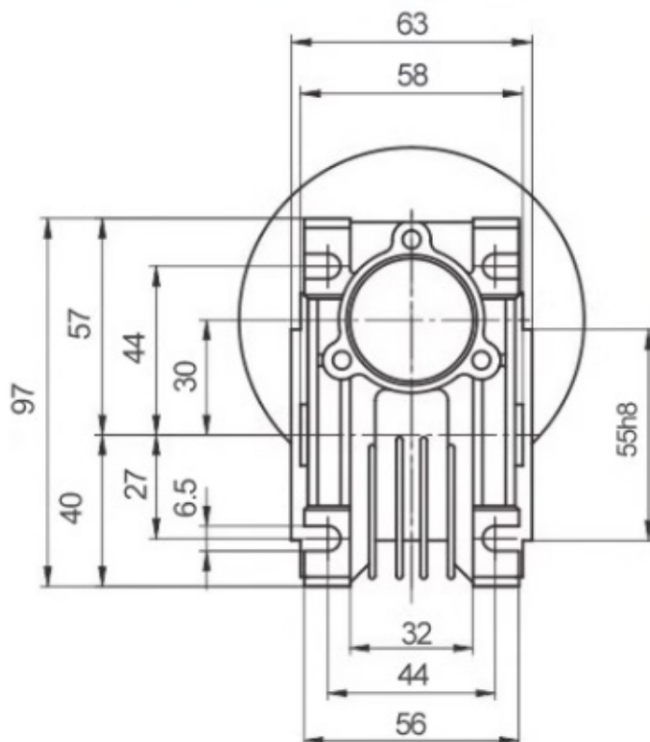
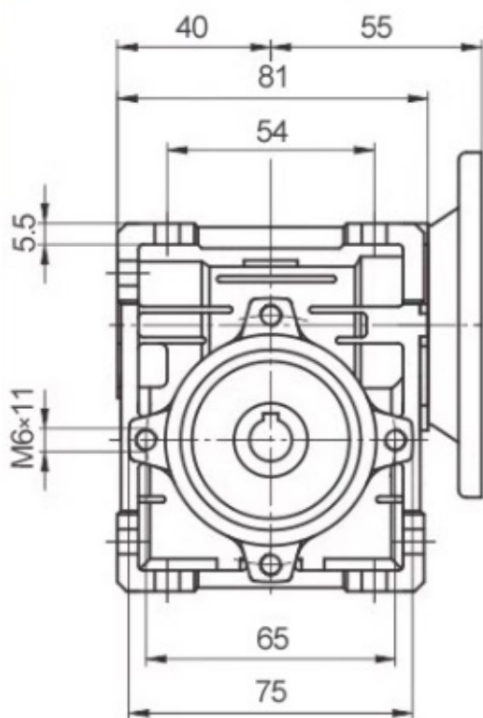

## NMRV030

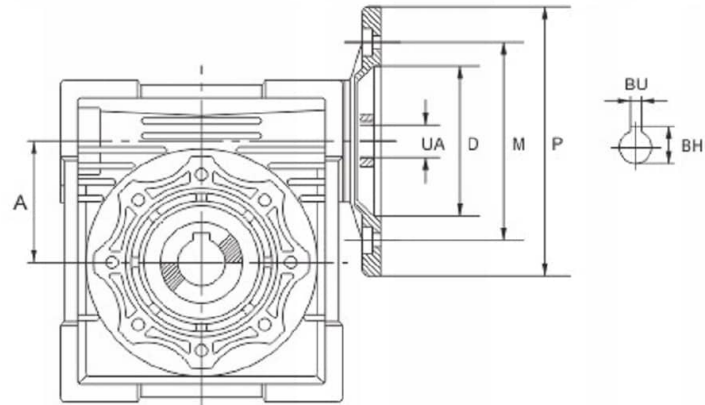

电机输入法兰 Motor Input Flange

中心轴 Center Distance A	电机法兰 Motor Flange						输入轴孔直径UA The Hole Diameter of Shaft										
	PAM IEC	D	M	P	BU	BH	传动比i Transmission Ratio										
							7.5	10	15	20	25	30	40	50	60	80	100
25	56B14	50	65	80	3	10.4	9	9	9	9	-	9	9	9	9	-	-
	63B5	95	115	140	4	12.8	11	11	11	11	11	11	11	11	-	-	-
30	63B14	60	75	90	3	10.4	9	9	9	9	9	9	9	9	9	9	-
	56B5	80	100	120	4	12.8	-	-	-	11	11	11	11	11	11	11	-
	56B14	50	65	80	3	10.4	-	-	-	-	-	-	-	9	9	9	9
	71B5	110	130	160	5	16.3	14	14	14	14	14	14	14	-	-	-	-
40	71B14	70	85	105	4	12.8	-	-	-	11	11	11	11	11	11	11	11
	63B5	95	115	140	4	12.8	-	-	-	11	11	11	11	11	11	11	11
	63B14	60	75	90	3	10.4	-	-	-	-	-	-	-	9	9	9	9
	56B5	80	100	120	3	10.4	-	-	-	-	-	-	-	9	9	9	9

## Parametry

## 5. 选型参数 Parameter Selections

### 5.1 单级减速机 (法兰输入, 输入转速1400r/min) / (配4极电机)

5.1 Single step reducer (flange input, input speed is 1400r/min)/(matched with 4 poles motor)

机型代号 Model code	输出转速 Output speed r/min	输出转矩 Output torque N.m	传动比 Transmission ratio i	输出轴径 向力 Output radial force kN	使用 系数 fs	机型代号 Model code	输出转速 Output speed r/min	输出转矩 Output torque N.m	传动比 Transmission ratio i	输出轴径 向力 Output radial force kN	使用 系数 fs	
025	<b>0.06kw</b>					030	<b>0.12kw</b>					
	186.7	2.6	7.5	0.5	4.2		140	6.7	10	0.75	2.7	
	140	3.4	10	0.55	3.5		93.3	9.5	15	0.86	1.9	
	93.3	4.9	15	0.63	2.5		70	12	20	0.94	1.5	
	70	6.1	20	0.69	2.0		56	14	25	1.02	1.5	
	46.7	8.2	30	0.79	1.6		46.7	16	30	1.08	1.3	
	35	10	40	0.87	1.3		35	19	40	1.19	0.9	
	28	12	50	0.94	0.9		28	23	50	1.28	0.8	
23.3	14	60	1	0.7	040	46.7	17.2	30	2.08	2.6		
030	186.7	2.6	7.5	0.68		6.9	35	21	40	2.29	1.9	
	140	3.4	10	0.75		5.4	28	25	50	2.47	1.5	
	93.3	4.7	15	0.86		3.8	23.3	28	60	2.63	1.3	
	70	6	20	0.94		3.0	17.5	34	80	2.89	1.0	
	56	7	25	1.02		3.0	14	38	100	3.11	0.8	
	46.7	8	30	1.08	2.5	050	23.3	29	60	3.61	2.3	
	35	9.7	40	1.19	1.9		17.5	35	80	3.97	1.9	
	28	11	50	1.28	1.5		14	40	100	4.28	1.4	
23.3	13	60	1.36	1.3	030	<b>0.18kw</b>						
17.5	14	80	1.5	0.9		186.7	7.8	7.5	0.68	2.3		
025	<b>0.09kw</b>					040	140	10	10	0.75	1.8	
	186.7	3.9	7.5	0.5			2.8	93.3	14	15	0.86	1.3
	140	5.1	10	0.55			2.4	70	18	20	0.94	1.0
	93.3	7.3	15	0.63			1.6	56	21	25	1.02	1.0
	70	9.2	20	0.69	1.3		46.7	24	30	1.08	0.8	
	46.7	12	30	0.79	1.1		050	70	19	20	1.82	2.0
	35	15	40	0.87	0.9			56	23	25	1.96	1.7
	030	186.7	3.9	7.5	0.68			4.6	46.7	26	30	2.08
140		5	10	0.75	3.6	35		32	40	2.29	1.3	
93.3		7.1	15	0.86	2.5	28		38	50	2.47	1.0	
70		9	20	0.94	2.0	23.3		43	60	2.63	0.8	
56		10	25	1.02	2.0	040	35	32	40	3.15	2.3	
46.7		12	30	1.08	1.7		28	39	50	3.39	1.9	
35		14	40	1.19	1.2		23.3	43	60	3.61	1.6	
28		17	50	1.28	1.0	17.5	52	80	3.97	1.2		
23.3	19	60	1.36	0.9	14	60	100	4.28	0.9			
040	28	19	50	2.47	2.0	<b>0.25kw</b>						
	23.3	21	60	2.63	1.7	186.7	11	7.5	1.31	3.6		
	17.5	26	80	2.89	1.3	140	14	10	1.44	2.8		
	14	29	100	3.11	1.0	93.3	21	15	1.65	1.9		
030	<b>0.12kw</b>					040	186.7	11	7.5	1.31	3.6	
	186.7	5.2	7.5	0.68	3.4		140	14	10	1.44	2.8	
						93.3	21	15	1.65	1.9		
						70	27	20	1.82	1.5		